

**GOAL**  
**SINGLE CYLINDER**  
**GK715H - GK716H - GK615H - GK616H**  
**GK515H - GK516H**



# SINGLE CYLINDER

GK715H - GK716H - GK615H - GK616H - GK515H - GK516H

**SBYS DEVICE**  
for automatic linking

**KNITTING HEAD**  
designed to knit high quality  
items and ensure constant  
reliability over time.

**NEW  
ELECTRONICS**  
with high  
resolution  
touch screen  
display

**NEW BASE**  
designed to increase  
solidity and rigidity,  
allows a more ergonomic  
assembling of  
components

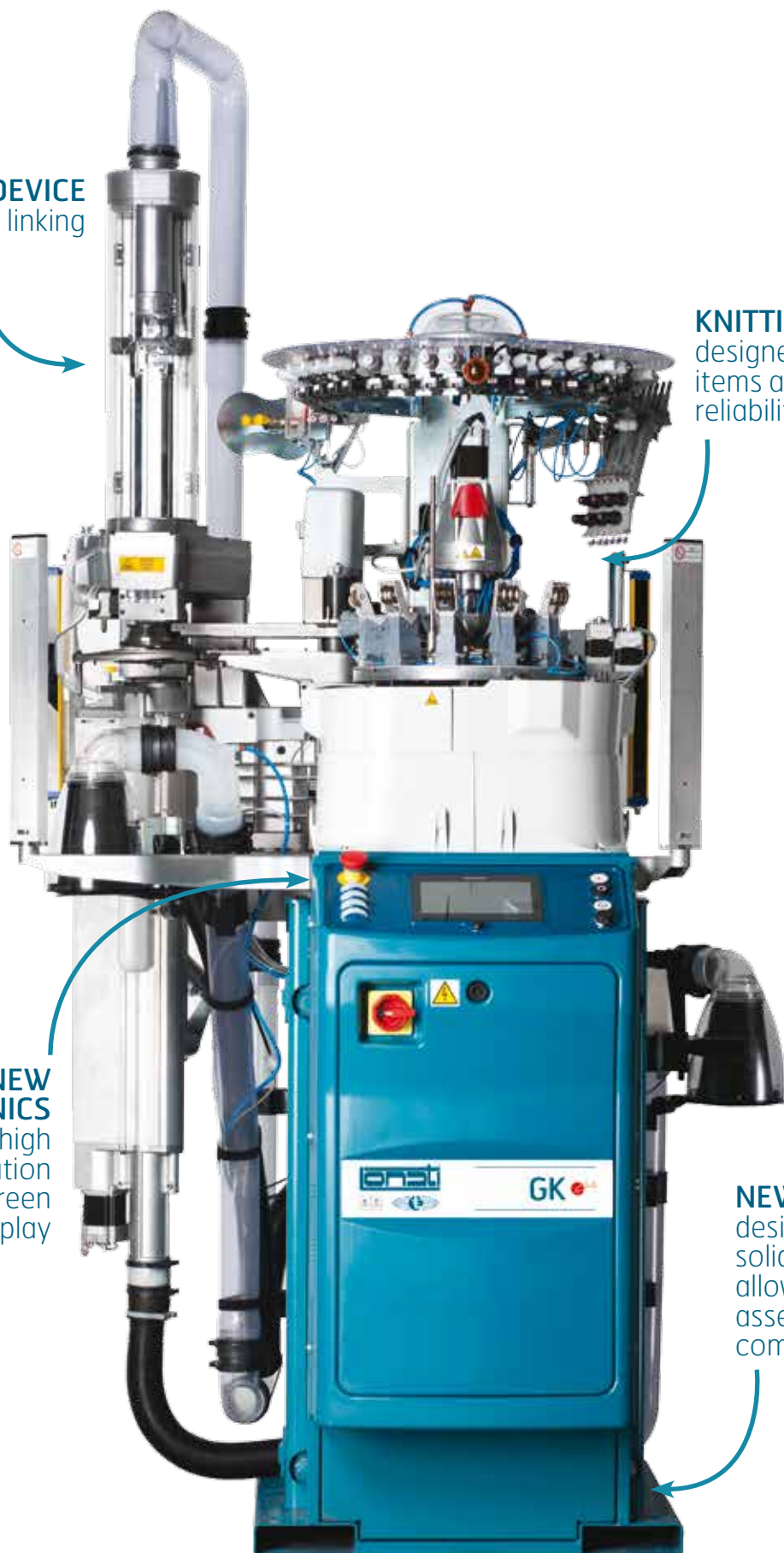

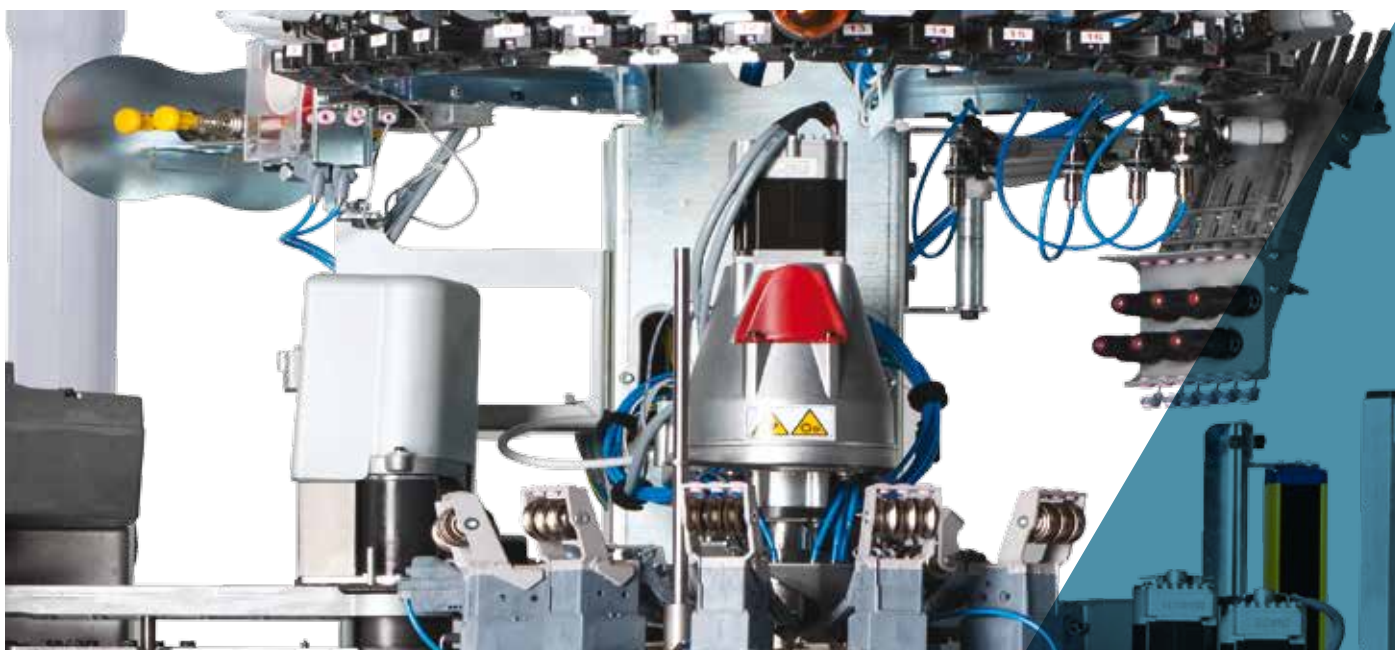

All images in this brochure are indicative and not binding.

# SINGLE CYLINDER

## GK715H - GK716H - GK615H - GK616H - GK515H - GK516H

1 feed machines are the best sellers of the Goal Line as, thanks to their versatility, they can produce several different items, from the very simple to the most complex, without compromising on quality and efficiency. Available in two versions, with five or six colors on course and in different diameters and numbers of needles. Automatic linking with SBYS device, performing a “real linking” technique. Advantages are remarkable: superior quality sock finishing, more comfort and resistance compared to socks made using conventional systems. Latest generation electronics provides control and execution of all machine commands. Drawings and articles are created and managed by Digraph 3 Plus software package, which contains a full collection of styles the operator can combine in different ways to obtain the desired results.

- 5 or 6 colors pattern on course according to the model, plain knit
- Reciprocated heel and toe in different sizes and 3D effects
- 25 or 28 yarnfingers, according to the model
- Rising dial and finger plate with stepping motor
- Electronic actuators for needle selection, 8 or 9 according to the model
- Brushless coaxial main motor

### MACHINE DIMENSIONS



Length max cm 127.3  
Depth max cm 114.8  
Height max cm 228

### MACHINE WEIGHT



ca. 320 Kg

### CERTIFICATION



Green  
Label

# SINGLE CYLINDER

GK715H - GK716H - GK615H - GK616H - GK515H - GK516H

## TECHNICAL DATA

MODEL	CYLINDER DIAMETER	GAUGE	NEEDLE THICKNESS
GK715H	3"1/2	7 1/2 to 20	0.85 - 0.70 - 0.60 mm
GK716H	3"1/2	7 1/2 to 20	0.85 - 0.70 - 0.60 mm
GK615H	3"3/4	9 to 20	0.85 - 0.70 - 0.60 mm
GK616H	3"3/4	9 to 20	0.85 - 0.70 - 0.60 mm
GK515H	4"	8 1/2 to 16	0.85 - 0.70 - 0.60 mm
GK516H	4"	8 1/2 to 19	0.85 - 0.70 - 0.60 mm

Above data are indicative and not binding.

## STANDARD DEVICES

- Stepper motor electric dial with adjustable height
- Stitch cam feed: 1 with 2 different heights.
- High speed sinkers cap
- High resolution touch screen display
- Yarn sliding sensors guard cleaning device
- Heel yarn recover device with four positions
- 2 stepper motor controlled adjustable suction valves
- 9 yarnfingers on stitch feed
- Yarn creel
- USB port
- 15 or 18 color yarnfingers, according to model
- Circular yarn cutter with mechanical stop
- 1 yarnfinger on laid-in elastic feed

## MAIN OPTIONAL DEVICES

- LGL Eco Power or Eco Compact yarn storage feeder
- Dinema YoYo positive yarn feeders
- Elastic yarn positive feeders, for compression socks
- Dinema Plus elastane positive feeders
- Stitch cams on first feed with 3 different heights
- Motorized stitch cams
- Motorized sinkers cap for sinkers pressure
- Motorized sinkers cap for sinkers pressure and angular position
- Antitwist device
- Footlet device
- Inside-out sock ejection device
- Elastane extra pliers device
- Yarn recover device, 6 positions
- Yarn trimming circular cutter with adjustable speed
- Linking device inspection lamp
- Preparation for storage feeder "Unifeeder 2" by
- BTSR
- Ethernet board for connection to Dinema Nautilus data collector system
- Second elastic yarn finger
- Yarn sliding control sensors, Dinema ISPY
- Pneumatic yarn tensioner for covered elastane
- Suction fan

## POSSIBLE KNITTING

The standard machine can perform the following knittings

- 5 or 6 colors pattern, according to model, plus ground, mesh, tuck and float stitch
- With laid-in elastic: 5 or 6 colors pattern, according to model, plus ground, tuck and float stitch
- With laid-in elastic: 4 or 5 colors pattern, according to model, plus ground, mesh, tuck and float stitch

# SINGLE CYLINDER

## GK715H - GK716H - GK615H - GK616H - GK515H - GK516H



### NUMBER OF COLORS

Number of colors	GK715H - GK615H - GK515H 5 colors on course plus ground GK716H - GK616H - GK616H 6 colors on course plus ground
------------------	--

### PERFORMANCES

	3" 1/2, 3" 3/4, 4" CYLINDERS
KNITTING FEATURES	Patterns or selections 300 rpm Plain knit without pattern 350 rpm
MAXIMUM SPEED	350 rpm

Above data are indicative and not binding.

**DISCLAIMER:** maximum speed may vary depending on yarn, knitting, lubrication etc

### GAUGE

		GAUGE																											
Model	ø	6½	7	7½	8	8½	9	9½	10	10½	11	11½	12	12½	13	13½	14	14½	15	15½	16	16½	17	17½	18	18½	19	20	
GK515H	4"					108		116		128	136	144		156	160		168	176	180	188	192	200				216	220		240
		Needle thickness 0.85 mm												Needle thickness 0.70 mm						Needle thickness 0.60 mm									
		Needle thickness 0.70 mm						Needle thickness 0.70 mm						Needle thickness 0.60 mm															
GK615H	3"3/4					108	112	116	120	128	132	136	144		156	160	168		176	180	188	192	200			216	220		240
		Needle thickness 0.85 mm												Needle thickness 0.70 mm						Needle thickness 0.60 mm									
		Needle thickness 0.70 mm						Needle thickness 0.70 mm						Needle thickness 0.60 mm															
GK715H	3"1/2		84	88	96	100		108	112	116	120	128	132		144		156		168			180		192	200				220
		Needle thickness 0.85 mm												Needle thickness 0.70 mm						Needle thickness 0.60 mm									
		Needle thickness 0.70 mm												Needle thickness 0.60 mm															

		GAUGE																												
Model	ø	6½	7	7½	8	8½	9	9½	10	10½	11	11½	12	12½	13	13½	14	14½	15	15½	16	16½	17	17½	18	18½	19	20		
GK516H	4"					108		116		128	136	144		156	160		168	176	180	188	192	200				216	220		240	
		Needle thickness 0.85 mm												Needle thickness 0.70 mm						Needle thickness 0.60 mm										
		Needle thickness 0.70 mm						Needle thickness 0.70 mm						Needle thickness 0.60 mm																
GK616H	3"3/4				96		108	112	116	120	128	132	136	144		156	160	168		176	180	188	192	200			216	220		240
		Needle thickness 0.85 mm												Needle thickness 0.70 mm						Needle thickness 0.60 mm										
		Needle thickness 0.70 mm						Needle thickness 0.70 mm						Needle thickness 0.60 mm																
GK716H	3"1/2		84	88	96	100		108	112	116	120	128	132		144		156		168			180		192	200				220	
		Needle thickness 0.85 mm												Needle thickness 0.70 mm						Needle thickness 0.60 mm										
		Needle thickness 0.70 mm												Needle thickness 0.60 mm																

Above data are indicative and not binding.

#### DISCLAIMER:

All features in the brochure are for information only and subject to change without any prior notice.  
For a complete list of available options, please contact Lonati sales network.  
The Company accepts no liability for improper use of machinery.

Lonati is recommending needles from  
**GROZ-BECKERT®**

# SINGLE CYLINDER

## GK715H - GK716H - GK615H - GK616H - GK515H - GK516H

### ELECTRIC POWER CONSUMPTION

With program for medium length socks.

MACHINE MODEL	CONSUMPTION kWh
GK715H - GK716H - GK615H - GK616H - GK515H - GK516H	0.45 – 0.50

### COMPRESSED AIR CONSUMPTION

Gauge pressure 6,5 bar humidity 0% and dryer outlet temperature 18°C-21°C.

MACHINE MODEL	CYCLE TIME	CONSUMPTION FOR STANDARD SOCK	CONSUMPTION FOR PANTYHOSE*	CONSUMPTION PERMINUTE FOR STANDARD SOCK	CONSUMPTION PER MINUTE FOR PANTYHOSE*
GK715H - GK716H - GK615H GK616H - GK515H - GK516H	3'00"	NI 25 - ft <sup>3</sup> 0.882	NI 35 - ft <sup>3</sup> 1.236	NI 8 - Cfm 0.282	NI 12 - Cfm 0.423

\*Sock ejection blow open

### SUCTION CONSUMPTION

Cylinder suction value = 850 mm/H2O - Holding yarns nozzle suction value = 850mm/H2O - Average consumption = 3 m<sup>3</sup>/min.

### NOISE LEVEL (Maximum noise output for GK series models)

Noise pressure level on reference surface = LPA 79,5 dB - Noise power level = LWA 96,6 dB - Peak= 109,3 dB

### LUBRICANTS

Average consumption for 100 dozens= 270 gr. Lonati recommends: Kluber Madol 183 Supreme - Fuchs Trax 16C

### GREASE

Foe seals, bearings etc: Lonati recommends:TechnolubeSeals Damping grease Nyogel 774F-1

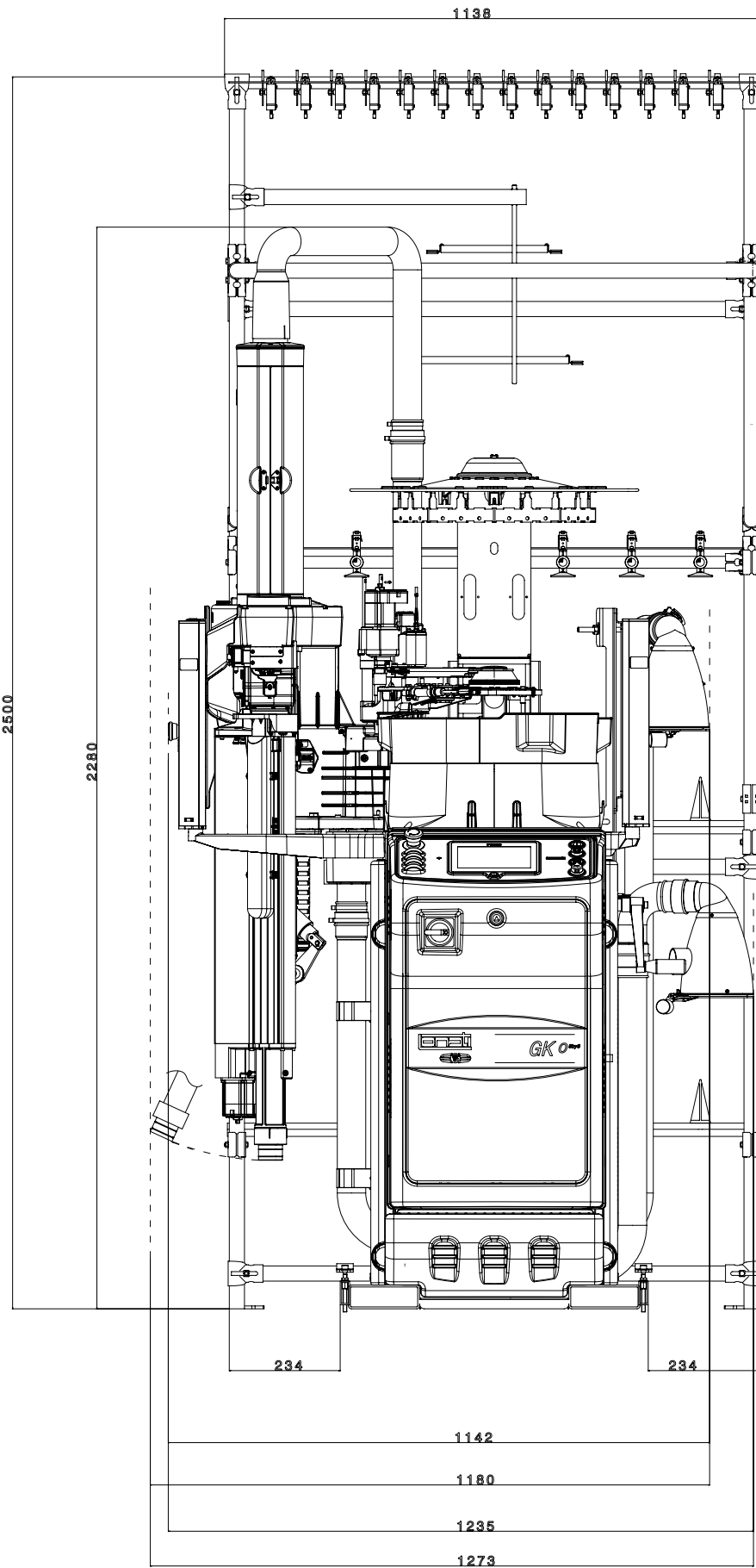

DESCRIPTION	CODE	NR. OF REELS	WEIGHT KG.	NOTES
Yarn creel	G3930061	28	51	Standard version
Yarn creel	G3930062	28	51	Version with BTR sensors



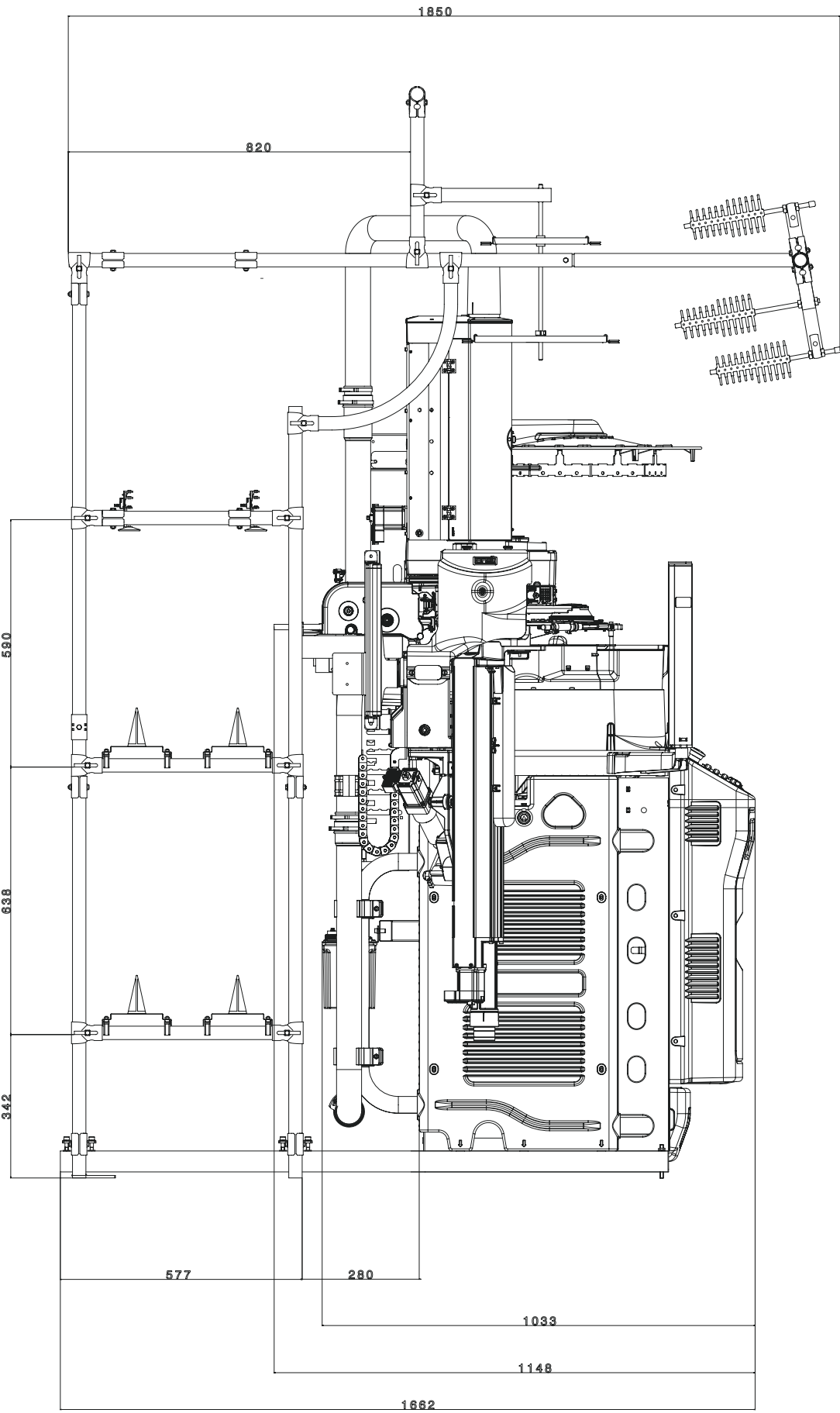

DESCRIPTION	CODE	NR. OF REELS	WEIGHT KG.	NOTES
Yarn creel	G3930061	28	51	Standard version
Yarn creel	G3930062	28	51	Version with BTSR sensors

# NOTE

GK715H - GK716H - GK615H - GK616H - GK515H - GK516H





**LONATI SPA**

Via Francesco Lonati, 3 | 25124 Brescia (Italy)  
Tel. +39 030 23901 | Fax +39 030 2310024  
C.F.: 01469680175 | P.iva: 02096730961  
info@lonati.com - www.lonati.com